

# INDUSTRIAL EQUIPMENT 2015/16 SPECIAL

WORKPLACE UP TO DATE



EXPRESS  
72h



## Drawer Cabinet

705 x 736 x 1019 mm (W x D x H)			R 24-24
ref.no.	Execution		Drawers
700/1122A	EA 100 kg	705 x 736 x 1019	1 x 75
700/1122AK	88% incl. dividing-kit		1 x 125 2 x 150
700/1122V8A	VA 80 kg	705 x 736 x 1019	2 x 200
700/1122V8AK	100% Cabinet 700/1122V8A incl. dividing-kit: 1 x fluted rubber mat, 1 x bins, 3 x metal dividers		

... more room to work

**bedrunka+hirth**  
BETRIEBSEINRICHTUNGEN

Standard colors



# Drawer Cabinets

depth 736 mm

705 x 736 x 1019 mm (W x D x H)

R 24-24

- Drawer simple extension 88% – load capacity 100 kg (SE)
- **Full extension 100% - load capacity 80 kg (FE)**
- Drawer inside dimension: 600 x 600 mm



**EXPRESS**  
72h

### Drawer Cabinet T736 R 24-24

- 9 x drawers

ref.no.	Execution
700/0900A	SE 88 %, 100 kg
700/0900V8A	<b>FE 100 %, 80 kg</b>

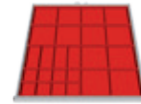

### Bins

- Front 100

ref.no.
134A



### Metal dividers

- Front 100

ref.no.
146BLH100A

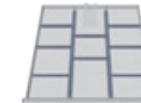

### Metal dividers

- Front 100

ref.no.
139BLH100A

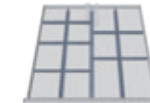

### Metal dividers

- Front 100

ref.no.
138BLH100A



**EXPRESS**  
72h

### Drawer Cabinet T736 R 24-24

- 6 x drawers

ref.no.	Execution
700/1131A	SE 88 %, 100 kg
700/1131V8A	<b>FE 100 %, 80 kg</b>

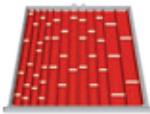

Front 50  
Plastic channel



Front 100  
Metal dividers



Front 150  
Metal dividers

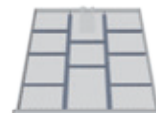

Front 150  
Metal dividers



### Drawer Cabinet T736 R 24-24

- 7 x drawers

ref.no.	Execution
700/1321A	SE 88 %, 100 kg
700/1321V8A	<b>FE 100 %, 80 kg</b>

## Combination

### Drawer Cabinet T736 R 24-24

- 1. 700 /1131A + 700/706A
- 2. 700 /1131V8A + 700/706A

Pos.	ref.no.	Execution
1	700/1131AK	SE 88 %, 100 kg
2	700/1131V8AK	<b>FE 100 %, 80 kg</b>

### Drawer Cabinet T736 R 24-24

- 1. 700 /1321A + 700/706A
- 2. 700 /1321V8A + 700/706A

Pos.	ref.no.	Execution
1	700/1321AK	SE 88 %, 100 kg
2	700/1321V8AK	<b>FE 100 %, 80 kg</b>

## CNC-Bench stands

CNC storage equipment

- 2 or 4 cassette in a screwed frame, shelf, rubber mat and grips



### Inserts

- This system is the most flexible available.
- The black plastic inserts are clipped into the heavy gauge steel tool carrier into a series of rebated slots.
- No fasteners are required to locate the inserts which can also be quickly removed simply by depressing the integral locking lug.

CNC E1	CNC E2	CNC E3
ISO / SK 30	SK 40	ISO / SK 50
Cyl / VDI 30	Cyl / VDI 40	VDI 50
MK3	HSK A 50 / B 63	HSK A 32 / B 40
MK4	HSK A 63 / B 80	HSK A 40 / B 50
Capto C 4	MK 5	HSK A 80 / B 100
	Capto C 5	HSK A 100 / B 125
		Universal
		Capto C 3
		Capto C 6
		Capto C 8

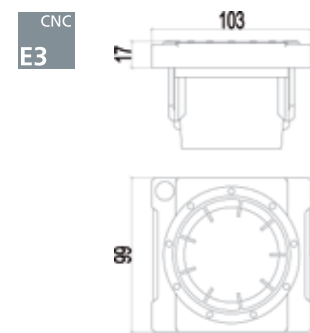
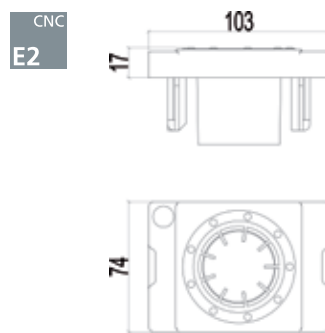
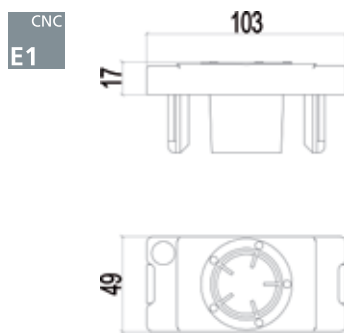

**EXPRESS**  
**72h**

### CNC-Bench stand TAG 2-1

- with 2 floors incl. inserts

ref.no.	Dimensions (W x D x H)	CNC E1	CNC E2	CNC E3
02.2210A	425 x 375 x 300	10/14*	10/10*	6/6*



**EXPRESS**  
**72h**

### CNC-Bench stand TAG 4-1

- with 2 floors incl. inserts

ref.no.	Dimensions (W x D x H)	CNC E1	CNC E2	CNC E3
02.2420A	425 x 375 x 525	20/28*	20/20*	12/12*

\* 1st figure: quantity of the inserts included type E1 or E2 or E3

2nd figure: maximum of the inserts possible in the carrier of each type E1 or E2 or E3

www.bedrunka Please, mention the tool inserts, without indication we supply ISO/SK 40.

# CNC tool storing systems

## CNC-Cabinets T500 R 36-16



### CNC double swing doors T500 R 36-16

- 3 tool frames
- 1 shelf
- including inserts acc. to chart

ref.no.	Dimensions (W x D x H)	CNC E1	CNC E2	CNC E3
02.2118.04/3A	980 x 500 x 1838	66/144*	66/99*	45/72*

### CNC-double swing doors T500 R 36-16

- 4 x CNC-Tool carrier (WAR)
- incl. CNC-inserts

ref.no.	Dimensions (W x D x H)	CNC E1	CNC E2	CNC E3
02.2118.04A	980 x 500 x 1838	80/192*	80/132*	52/96*



### CNC-roller shutter cabinet T500 R 36-16

- Aluminum-Roller
- 4 x CNC-Tool carrier (WAR)
- incl. CNC-inserts

ref.no.	Dimensions (W x D x H)	CNC E1	CNC E2	CNC E3
02.289.00A	1000 x 500 x 1950	80/192*	80/132*	52/96*

### CNC-Roller shutter cabinet T500 R 36-16

- Aluminum-Roller
- 3 x CNC-Tool carrier (WAR)
- 1 x shelf
- CNC-inserts

ref.no.	Dimensions (W x D x H)	CNC E1	CNC E2	CNC E3
02.289.01/3A	1000 x 500 x 1950	66/144*	66/99*	45/72*

### CNC-Roller shutter cabinet T500 R 36-16

- Plastic Roller
- 4 x CNC-Tool carrier (WAR)
- incl. CNC-inserts

ref.no.	Dimensions (W x D x H)	CNC E1	CNC E2	CNC E3
02.295.00A	1000 x 500 x 1950	80/192*	80/132*	52/96*

### CNC-Roller shutter cabinet T500 R 36-16

- Plastic Roller
- 3 x CNC-Tool carrier (WAR)
- 1 x shelf
- incl. CNC-inserts

ref.no.	Dimensions (W x D x H)	CNC E1	CNC E2	CNC E3
02.295.01/3A	1000 x 500 x 1950	66/144*	66/99*	45/72*

\* 1st figure: quantity of the inserts included type E1 or E2 or E3  
 2nd figure: maximum of the inserts possible in the carrier of each type E1 or E2 or E3  
 Please, mention the tool inserts, without indication we supply ISO/SK 40.

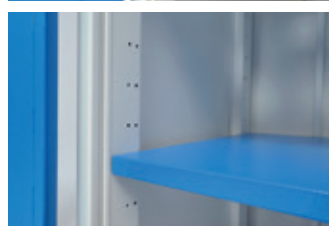

**CNC-Transport systems**

CNC storage equipment

**Optimal storage and transport**



50 SE  
100 SE  
150 SE  
400 FE



**CNC-mobile drawer cabinet T736 R 18-24**

- 1 x CNC-drawer frame 450 (SR)
- incl. CNC-inserts
- WxDxH: 555 x 736 x 975 mm

ref.no.	CNC E1	CNC E2	CNC E3
02.2580.04RB	25/35*	25/25*	15/15*

**CNC-Trolley for tool carriers**

- 6 x CNC-Tool carrier 600 (WAT)
- 1 x shelf at the bottom
- incl. CNC-inserts
- The 2 bottom CNC-Tool carriers (WAT)
- can be removable.
- WxDxH: 630 x 900 x 860 mm

ref.no.	CNC E1	CNC E2	CNC E3
02.288.06A	42/60*	42/42*	25/30*

**CNC-Trolley**

- 4 x CNC wide tool holders
- 4 x CNC narrow tool holders
- 1 x top shelf
- incl. CNC-inserts
- WxDxH: 990 x 610 x 1450 mm

ref.no.	CNC E1	CNC E2	CNC E3
02.58.44A	84/192*	84/132*	64/96*



**CNC-mobile cabinet**

- 6 x CNC-Tool carrier 600 (WAT)
- incl. CNC-inserts

ref.no.	Maße in mm (B x T x H)	CNC E1	CNC E2	CNC E3
02.285.07A	560 x 630 x 950	30/60*	30/42*	20/30*



**CNC-mobile cabinet**

- 6 x CNC-Tool carrier 900 (WAT)
- incl. CNC-inserts

ref.no.	Maße in mm (B x T x H)	CNC E1	CNC E2	CNC E3
02.285.01A	560 x 930 x 950	48/96*	48/66*	34/48*

**CNC-Shed**

- locking with cylinder lock

ref.no.	Maße in mm (B x T x H)	CNC E1	CNC E2	CNC E3
02.86.07A	705 x 736 x 1019	—	—	—

**CNC-Shed**

- locking with cylinder lock

ref.no.	Maße in mm (B x T x H)	CNC E1	CNC E2	CNC E3
02.86.01A	705 x 1003 x 1019	—	—	—

\*Delivered without tool

# Workbenches and workstations

## Workbenches R 18-24

- Drawers Extension 88% – load capacity 100 kg (EA)
- Drawer inside dimensions: 450 x 600 mm
- Total load capacity 1200 kg



- Worktop beech multiplex 40 mm
- left: 1 x drawer, 1 x hinged doors
- middle: 1 x shelf in half depth, back panel
- right: 1 x drawer, 1 x wing door

ref.no.	Dimensions (W x D x H)	Extension
03.19.22A	2000 x 750 x 859	Workbench
03.81.104A	2000 x 450	perforated panel

**EXPRESS**  
**72h**

- Worktop beech multiplex 40 mm
- left: 1 x drawer 150 mm, 1 x hinged doors 450 mm
- middle: shelf in half depth, back panel
- right: 3 x drawers



ref.no.	Dimensions (W x D x H)
03.19.24A	2000 x 750 x 859

- Worktop beech multiplex 40 mm
- left: 1 x drawer, 1 x hinged doors
- middle: 1 x shelf in half depth, back panel
- right: 4 x drawers



ref.no.	Dimensions (W x D x H)
03.19.26A	2000 x 750 x 859

## Accessories



### Metal dividers

- Front 150

ref.no.
115A



### Metal dividers

- Front 150

ref.no.
113A



### Metal dividers

- Front 150

ref.no.
117A

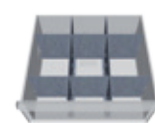

### Metal dividers

- Front 200

ref.no.
118A

## Workbenches R 24-24

Workbenches and workstations

- Drawers Extension 88% – load capacity 100 kg (EA)
- Drawer inside dimensions: 600 x 600 mm
- Total load capacity 1200 kg



- Worktop beech multiplex 40 mm
- left: 1 x hinged doors 600 mm, 1 x support
- right: 4 x drawers
- perforated panel (without hooks)

ref.no.	Dimensions (W x D x H)	Extension
03.15.19A	1500 x 750 x 859	Workbench
03.81.103A	1500 x 450	Perforated panel

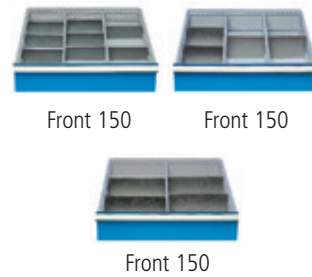

### Dividing set

- 3 x metal dividers

ref.no.
03.50.03A

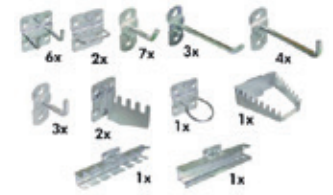

### Set of 31 hooks

- 31 pieces

ref.no.
03.82.395A

## Combinations

### Workbench T736 R 24-24

- consists of 03.15.19A + 03.50.03A + 03.82.395A + 03.81.103A

**EXPRESS**  
**72h**

ref.no.	Dimensions (W x D x H)
03.15.19K	1500 x 750 x 1309



- Worktop beech multiplex 40 mm
- left: 1 x hinged doors, 1 x shelf
- right: 3 x drawers

ref.no.	Dimensions (W x D x H)
03.15.17A	1500 x 750 x 859



- Worktop beech multiplex 40 mm
- left: 2 x compartment, 1 x shelf
- right: 3 x drawers

ref.no.	Dimensions (W x D x H)
03.15.03A	1500 x 750 x 859



- Worktop beech multiplex 40 mm
- left: 1 x drawer, 1 x hinged doors
- right: 1 x drawer, 1 x hinged doors

ref.no.	Dimensions (W x D x H)
03.15.01A	1500 x 750 x 859



- Worktop beech multiplex 40 mm
- left: 3 x drawers
- right: 4 x drawers

ref.no.	Dimensions (W x D x H)
03.15.34A	1500 x 750 x 859

**EXPRESS**  
**72h**

# Mobile Logistic-Systems

## Mobile workbench T500 R 24-16

- Drawers Extension 100%
- Load capacity 50 kg
- Drawer inside dimensions: 600 x 400 mm
- 4 wheels Ø 125 mm, 2 with brake
- Grab handle



- 5 x drawers
- weight 90 kg

ref.no.	Dimensions (W x D x H)
68.221AM	680 x 500 x 1004



- 7 drawers
- weight 102 kg

ref.no.	Dimensions (W x D x H)
68.700AM	680 x 500 x 1004

## Mobile workbench T750 mm R 18-24



### Mobile Workbench T736 R 18-24

- 4 x drawers
- 1 x hinged door, 1 x shelf
- Worktop beech multiplex 25 mm
- 140 kg

ref.no.	Dimensions (W x D x H)
04.12.19A	1250 x 750 x 935



**bedrunka+hirth**  
BETRIEBSEINRICHTUNGEN

**EXPRESS**  
**72h**

Shipment 72 hrs



### Fluted rubber

- 450 x 600 mm

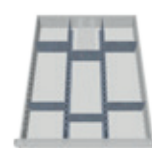

### Bins

- Front 100 - 150

### Metal dividers

- Front 150

### Dividing set T736 R 18-24

- for 3 x drawers

ref.no.
500/583A

Offers apply to commercial and craft activities. Technical and price modification are possible given the price of raw material. The price is calculated without TVA, except mistakes or omission.



ENPRAG s.r.o.  
K Holyni 833/42  
154 00 Praha 5 - Slivenec  
tel.: 224 942 663 | fax: 224 941 053  
www.kovovynabytek.cz