



HIGH SECURITY Safes

Premium
Catalogue 2018





Business growth leaders in 2017



Seal of Aragon Social Responsibility 2017



AES Association Member



European Security Systems Association



Pilot Prize for Logistics Excellence



Zaragoza Factory



Finished product line



Laser cutting machine CNC



Finished product warehouse

Index

CERTIFIED SAFES

Babylon - Grade II	2-3
Athenas - Grade III	4-5
Luxor - Grade IV	6-7
Thebas - Grade IV	8-9
Alexandria - Grade V	10



New Babylon series

SAFES FOR SPECIFIC USES

Athenas 175 - Grade III	12
Athenas AC 30 - Grade III	13
Safe Deposit Boxes	14



Athenas 175 and Athenas AC 30 gunsafes

INTERESTING DATA

European Safe standards	16
-------------------------------	----

NEW

BABYLON



Features



High security safes series certified by ECBS with Grade II of resistance to theft in accordance with the UNE EN-1143-1:2012 standard (ECBS 1308/SA18-01 certificate).

Door shielding thickness: 50 mm.

Body thickness: 40 mm.

Body armoring made of vandal-proof high-resistance concrete with steel fibers.

Colour: Light gray (RAL 7047)



Colours on request:

Blue Gray (RAL 5008)



Red Wine (RAL 3005)



Blue Cobalt (RAL 5013)



Violet (RAL 4007)



Anchor holes: 3 holes to floor, ensuring maximum stability and resistance



Babylon 150 K

Locking system

K Model: Double bitted key lock (VdS Class 1, A EN-1300).

E Model: Double bitted key lock and electronic lock. VdS Class 2, B EN-1300 (ANSI/UL-768 1R)

Bolts: Ø35 mm distributed around the perimeter of the door.

Power: 9V Battery (6LR61). Model E.

Door opening: 180°.



Babylon 50 E

Models

E Models





- electronics

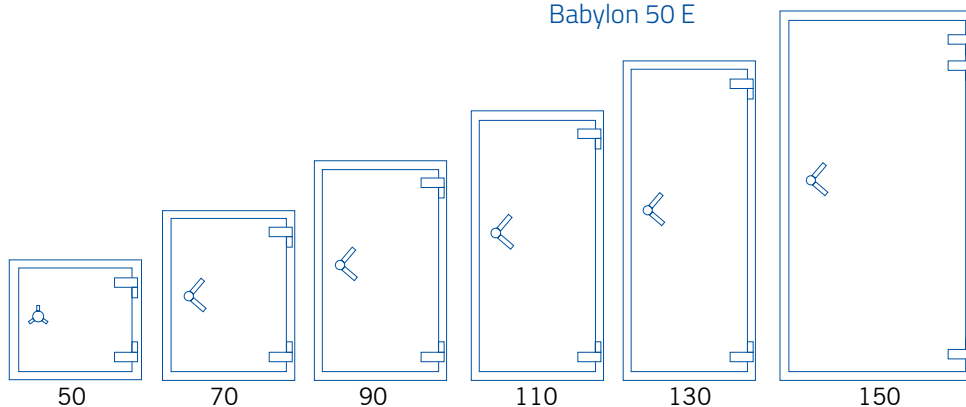

K Models

- key



Model	Code	 Ext (Hi x Wi x D)	 Int (Hi x Wi x D)			L
50 E 50 K	11150 11160	480 530 510	400 450 344	2	220	65
70 E 70 K	11151 11161	680 530 510	600 450 344	2	290	95
90 E 90 K	11152 11162	880 530 510	800 450 344	3	340	125
110 E 110 K	11153 11163	1080 530 510	1000 450 344	4	420	155
130 E 130 K	11154 11164	1280 530 510	1200 450 344	4	480	190
150 E 150 K	11155 11165	1480 780 600	1400 700 434	5	770	425

Exclusive options

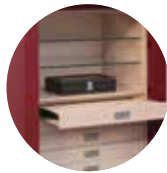

Internal drawers



Jewellery drawer

Internal paneling:

Attractive internal paneling with drawers 8 cm or 15 cm high and sliding rails that can be pulled out completely.

Glass shelves in the upper part (except for models 50 and 70).

Internal lighting with battery powered energy saving LEDs.

Removable cover for easy installation of the box to the floor.

Interior cabinet finishings:

Acacia  Cinder  Cherry tree 

Exterior finish, mirror gloss colours:

White mirror  Black mirror 



Accessories

Integra accessories	Model	Description	Code
Individual secreter with lock	50 to 130	1 to 2 secreters per box width	70381
	150	1 to 3 secreters per box width	70382
Lockable drawer module	50 to 130	1 Simple drawer	70383
	150	1 Double drawer	70384
Short weapon compartment module	50 to 130	5 Compartments	70385
	150	8 Compartments	70386
Special width trays	50 to 130	1/2 Width tray	70376
	150	2/3 Width tray	70377

*These trays serve to complement the width of an individual secreter

Accessories	Model	Code
Additional trays	50 to 130	70374
	150	70375
Anchorage pad*	50 to 130	11171
	150	11172
Pad installation kit		10049

*According to the standard UNE 108136 and Ministerial Order 317/2011, for safes with a weight under 2000 kg. Anchoring pad thickness: 30 mm.



Features



High security safes with grade III burglary protection according to the UNE EN-1143-1:2012 standard certified by AENOR. (Certificate no.055/000099). Suitable for business use in order to keep valuables or weapons secure with high security level.

Door shielding thickness: 40 mm.

Body thickness: 40 mm and 60 mm (mod.150-175)

Body armouring made of vandal-proof high-resistance concrete with steel fibers.

Colour: Blue Gray (RAL 5008)



Colours on request:

Red Wine (RAL 3005)



Blue Cobalt (RAL 5013)



Violet (RAL 4007)



Anchor holes: 1 floor.

Locking system

K Model: Double bitted key lock (VdS Class 2, B EN-1300)

E Model: Double bitted key lock and electronic lock, VdS Class 2, B EN-1300 (ANSI/UL-768 1R)

BL Model: Double bitted key lock and electronic lock, VdS Class 2, B EN-1300 (ANSI/UL-768 1R) and programmable time delay up to 99 minutes. 168 hours locking system (7 days).

Re-lock: In case of violent attack, several re-locks systems disable all closure elements.

Bolts: Ø35 mm distributed around the perimeter of the door.

Power: 9V Battery (6LR61). Models BL and E.

Door opening: 180°.



Models

BL Models

- key
- electronics
- time delay



E Models

- key
- electronics



K Models

- key

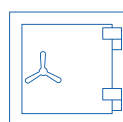

40

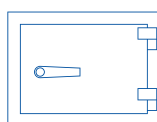

45

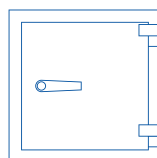

60

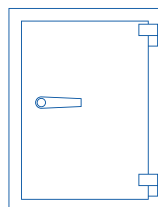

80

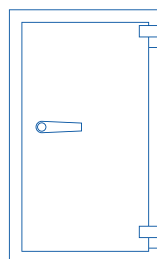

100

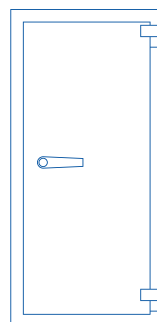

125

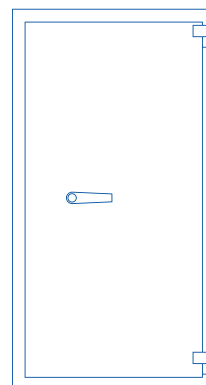

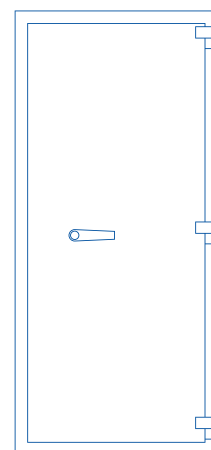

150



175

Athenas 125 BL

Model	Code		Ext (Hi x Wi x D)				Int (Hi x Wi x D)				L
40 BL	10801										
40 E	10729	450	450	400	370	370	250	2	125	38	
40 K	10779										
45 BL	10802										
45 E	10742	450	600	550	370	520	400	2	200	65	
45 K	10771										
60 BL	10803										
60 E	10743	600	600	550	520	520	400	2	250	110	
60 K	10772										
80 BL	10804										
80 E	10744	800	600	550	720	520	400	2	350	140	
80 K	10773										
100 BL	10805										
100 E	10745	1000	600	550	920	520	400	3	450	190	
100 K	10774										
125 BL	10806										
125 E	10746	1250	600	550	1170	520	400	4	550	245	
125 K	10775										
150 BL	10807										
150 E	10747	1540	840	670	1420	720	500	5	1100	510	
150 K	10776										
175 BL	10808										
175 E	10748	1790	840	670	1670	720	500	6	1250	600	
175 K	10777										

Exclusive options



Internal drawers



Jewellery drawer

Internal paneling:

Attractive internal paneling with drawers 8 cm or 15 cm high and sliding rails that can be pulled out completely. Glass shelves in the upper part (except for models 40 to 60). Internal lighting with battery powered energy saving LEDs.

Removable lining to facilitate anchoring the safe to the floor.

Interior cabinet finishings:



Acacia



Cinder



Cherry tree

Accessories

Accessories	Model	Code
Additional trays	45 to 125	70372
	150 to 195	70373
Anchorage pad*	40	10045
	45 to 125	10047
	150 to 175	10048
Pad installation kit		10049

*According to the standard UNE 108136 and Ministerial Order 317/2011, for safes with a weight under 2000 kg. Anchoring pad thickness: 30 mm.



Features



High security safe with grade IV. Tested by Applus and certified by AENOR UNE EN-1143-1:2012 standard (certificate no. 055/000043)

Ideal for private security business use. It complies with the INT/317/2011 Order of the Spanish Official Gazette no.42 (18th February 2011), as well as business where valuables need to be kept at very high security level.

Door shielding thickness: 80 mm.

Body thickness: 80 mm.

Body armoring made of stainless steel and double body filled of vandal proof high-resistance concrete with steel fibers.

Colour: Blue Gray (RAL 5008)



Colours on request:

Red Wine (RAL 3005)



Blue Cobalt (RAL 5013)



Violet (RAL 4007)



Anchor holes: 1 floor.

Locking system

2K Model: Double bitted key lock (VdS Class 2, B EN 1300)

E Model: Double bitted key lock and electronic lock, VdS Class 2, B EN-1300 (ANSI/UL-768 1R)

BL Model: Double bitted key lock and electronic lock, VdS Class 2, B EN-1300 (ANSI/UL-768 1R) and programmable time delay up to 99 minutes. 168 hours locking system (7 days).

Re-lock: In case of violent attack, several re-locks systems disable all closure elements.

Bolts: Ø35 mm distributed around the perimeter of the door.

Power: 9V Battery (6LR61). Models BL and E.

Door opening: 180°.



Luxor 800 BL

Models

BL Models

- key
- electronics
- time delay



E Models

- key
- electronics



2K Models

- 2 keys

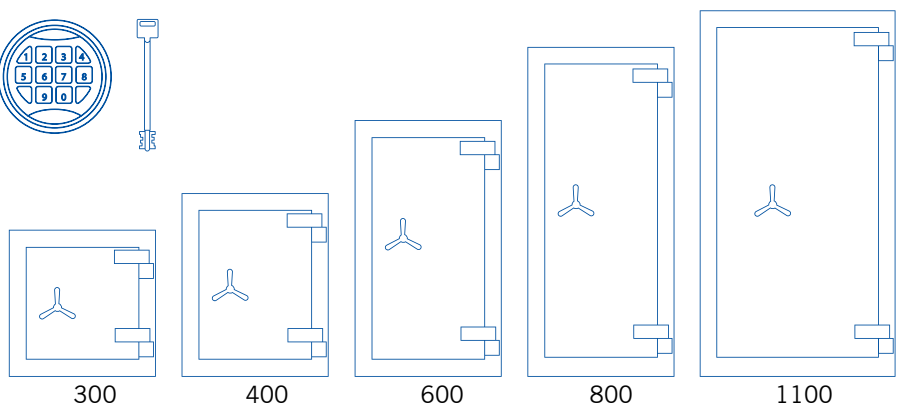





300

400

600

800

1100

Model	Code	 Ext (Hi x Wi x D)	 Int (Hi x Wi x D)			L
300 BL 300 E 300 2K	10096 10040 10050	600 600 550	440 440 320	2	390	64
400 BL 400 E 400 2K	10097 10041 10051	750 600 550	590 440 320	2	460	83
600 BL 600 E 600 2K	10098 10042 10052	1050 600 550	890 440 320	3	630	129
800 BL 800 E 800 2K	10099 10043 10053	1350 600 550	1190 440 320	4	800	173
1100 BL 1100 E 1100 2K	10100 10044 10054	1500 800 650	1340 640 420	5	1180	369

Exclusive options



Internal paneling:

Attractive internal paneling with drawers 8 cm or 15 cm high and sliding rails that can be pulled out completely. Glass shelves in the upper part (except for model 300). Internal lighting with battery powered energy saving LEDs.

Removable lining to facilitate anchoring the safe to the floor.

Interior cabinet finishings:



Acacia



Cinder



Cherry tree



Shelves and lighting



Internal drawers

Accessories

Accessories	Model	Code
Additional trays	300 to 800	70370
	1100	70371
Anchorage pad*	300 to 800	10047
	1100	10048
Pad installation kit		10049

*According to the standard UNE 108136 and Ministerial Order 317/2011, for safes with a weight under 2000 kg. Anchoring pad thickness: 30 mm.



Features



High security safe with grade IV. Tested by Applus and certified by AENOR UNE EN-1143-1:2012 standard (certificate no. 055/000098).

Ideal for private security business use. It complies with the INT/317/2011 Order of the Spanish Official Gazette no.42 (18th February 2011), as well as jewellery stores, lottery dealers, amusement arcades, bank offices, houses and business where valuables need to be kept at a very high security level.

Door shielding thickness: 40 mm.

Body thickness: 40mm (mod.45-125) and 60 mm (mod.150)

Body armoured made of stainless steel and double body filled of vandal proof high-resistance concrete with steel fibers.

Colour: Blue Gray (RAL 5008)



Colours on request:

Red Wine (RAL 3005)



Blue Cobalt (RAL 5013)



Violet (RAL 4007)



Anchor holes: 1 floor.

Locking system

2K Model: Double bitted key lock (VdS Class 2, B EN-1300)

E Model: Double bitted key lock and electronic lock, VdS Class 2, B EN-1300 (ANSI/UL-768 1R)

BL Model: Double bitted key lock and electronic lock, VdS Class 2, B EN-1300 (ANSI/UL-768 1R) and programmable time delay up to 99 minutes. 168 hours locking system (7 days).

Re-lock: In case of violent attack, several re-locks systems disable all closure elements.

Bolts: Ø35 mm distributed around the perimeter of the door.

Power: 9V Battery (6LR61). Models BL and E.

Door opening: 180°.



Thebas 100 BL

Models

BL Models

- key
- electronics
- time delay



E Models

- key
- electronics



2K Models

- 2 keys

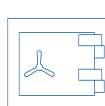
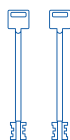

45 XS

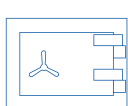

45

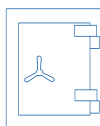

60 XS

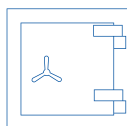

60

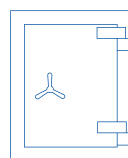

80

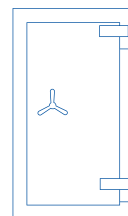



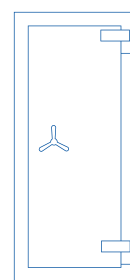

100

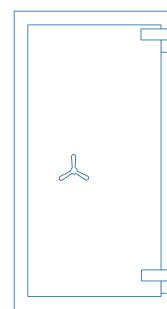

125



150

Model	Code		Ext (Hi x Wi x D)				Int (Hi x Wi x D)					L
45 XS BL	11017											
45 XS E	11027	450	450	400	370	370	250	2	150	38		
45 XS 2K	11037											
45 BL	11019											
45 E	11029	450	600	550	370	520	400	2	200	65		
45 2K	11039											
60 XS BL	11018											
60 XS E	11028	600	450	400	520	370	250	2	200	48		
60 XS 2K	11038											
60 BL	11020											
60 E	11030	600	600	550	520	520	400	2	250	110		
60 2K	11040											
80 BL	11021											
80 E	11031	800	600	550	720	520	400	2	350	140		
80 2K	11041											
100 BL	11022											
100 E	11032	1000	600	550	920	520	400	3	450	190		
100 2K	11042											
125 BL	11023											
125 E	11033	1250	600	550	1170	520	400	4	550	245		
125 2K	11043											
150 BL	11024											
150 E	11034	1540	840	670	1420	720	500	5	1100	510		
150 2K	11044											

Exclusive options



Internal drawers



Jewellery drawer

Internal paneling:

Attractive internal paneling with drawers 8 cm or 15 cm high and sliding rails that can be pulled out completely. Glass shelves in the upper part (except for models 45XS to 60). Internal lighting with battery powered energy saving LEDs.

Removable lining to facilitate anchoring the safe to the floor.

Interior cabinet finishings:



Acacia



Cinder



Cherry tree

Accessories

Accessories	Model	Code
Additional trays	45 to 125	70372
	150	70373
Anchorage pad*	45-60 XS	10045
	45 to 125	10047
	150	10048
Pad installation kit		10049

* According to the standard UNE 108136 and Ministerial Order 317/2011, for safes with a weight under 2000 kg. Anchoring pad thickness: 30 mm.



Features



High security safe series certified by ECB-S Grade V protection against burglary according to European standard UNE EN 1143-1:2012.

Designed to protect documents and valuables against burglary.

Door shielding thickness: 166 mm.

Body thickness: 71mm.

Body armoring made by an interior frame and body filled of vandal proof high-resistance concrete with steel fibers.

Colour: Light grey (RAL 7035)

Anchor holes: 1 floor.

Locking system

2K Model: Double bitted key lock (VdDS Class 2, B EN-1300)

E Model: Double bitted key lock and electronic lock, VdS Class 2, B EN-1300 (ANSI/UL-768 1R)

BL Model: Double bitted key lock and electronic lock, VdS Class 2, B EN-1300 (ANSI/UL-768 1R) and programmable time delay up to 99 minutes. 168 hours locking system (7 days).

Drilling attack guaranteed lock.

Bolts: 8 to 12 x Ø 35 mm distributed in 3 sides.



Alexandria 85 E

Models

BL Models

- key
- electronics
- time delay



E Models

- key
- electronics



2K Models

- 2 keys

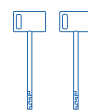

Exclusive options

For exclusive options in this model consult pages 9, 11 or 13.

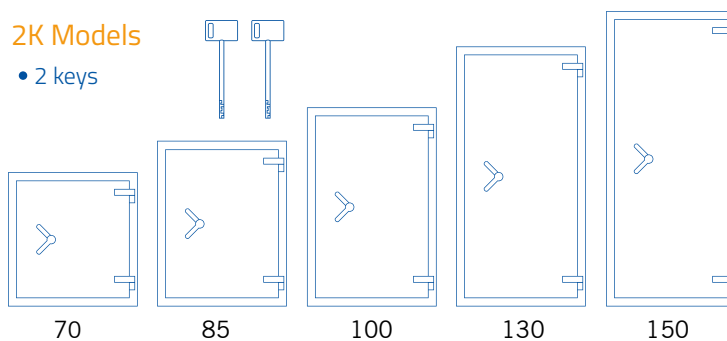

Model	Code		Ext (Hi x Wi x D)				Int (Hi x Wi x D)					L
70 BL	12000											
70 E	12005	680	680	620	540	540	382	1	672	111		
70 2K	12010											
85 BL	12001											
85 E	12006	840	680	670	700	540	432	1	883	163		
85 2K	12011											
100 BL	12002											
100 E	12007	1010	680	670	870	540	432	2	970	203		
100 2K	12012											
130 BL	12003											
130 E	12008	1320	680	670	1180	540	432	3	1230	275		
130 2K	12013											
150 BL	12004											
150 E	12009	1510	680	670	1370	540	432	3	1385	320		
150 2K	12014											

Safes for specific uses



Athenas 175 (Armour)	12
Athenas AC 30	13
Safe Deposit Boxes	14
Gas Station	15

NEW

ATHENAS 175 gunsafe(Armour)



Features



Gun safe for short and long weapons custody.
High security gunsafe series certified by AENOR. Grade III burglary protection according to the European standard UNE EN 1143-1:2012 (certificate no. 055/000099).

The interior layout can be configured with a modular system of compartments, drawers and spaces for guns according to the customer's needs.

Door shielding thickness: 40 mm.

Body thickness: 60 mm.

Body armouring made of vandal-proof high-resistance concrete with steel fibers.

Colour: Blue Gray (RAL 5008)

Anchor holes: 2 floor / 2 wall.

Locking system

K Model: Double bitted key lock (VdS Class 2, B EN-1300)

E Model: Double bitted key lock and electronic lock, VdS Class 2, B EN-1300 (ANSI/UL-768 1R)

Re-lock: In case of violent attack, several re-locks systems disable all closure elements.

Bolts: Ø35 mm distributed around the perimeter of the door.

Power: 9V Battery (6LR61). Model E.

Door opening: 180°.



Interior layout example

Armour 175-E

Configurations

Accessories	Useful dimensions Hi x Wi x D			L.	Code
Short weapon compartment module	154	237	200	7,3	10812
Drawer	84	402	217	7,5	10813

*Both with mechanical lock masterkeyed



Compartment + Drawer



Long gun holder

Models

K Models

- key



E Models

- electronics



Model	Code	Ext (Hi x Wi x D)			Int (Hi x Wi x D)			kg	L
Armour 175-E	10810	1790	640	420	1670	520	250	765	217
Armour 175-K	10811								



ATHENAS AC 30 gunsafe



AC-3030-E



AC-3040-K

Features

High security gunsafe series certified by AENOR. Grade III burglary protection according to the European standard UNE EN 1143-1:2012 (certificate no. 055/000099).

Suitable for business use where valuables or weapons need to be kept with a high security level. It complies with the INT/314/2011 order of the Spanish official Gazette no. 42 (18th February 2011).

Door shielding thickness: 40 mm.

Body thickness: 40mm.

Body armoring made of vandal-proof high-resistance concrete with steel fibers.

Colour: Blue Gray (RAL 5008)

Anchor holes: 2 floor / 2 wall.

Locking system

K Model: Double bitted key lock (VdS Class 2, B EN-1300)

E Model: Double bitted key lock and electronic lock, VdS Class 2, B EN-1300 (ANSI/UL-768 1R)

Re-lock: In case of violent attack, several re-locks systems disable all closure elements.

Bolts: Ø25 mm distributed around the perimeter of the door.

Power: 9V Battery (6LR61). Model E.

Door opening: 180°.

Models

Models K

- key



Models E

- electronics
- key

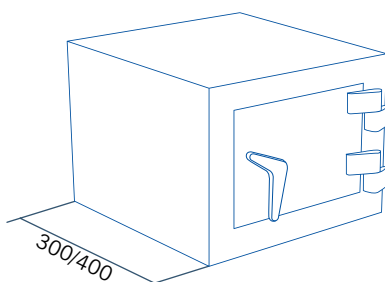

Model	Code	Ext (Hi x Wi x D)			Int (Hi x Wi x D)					L
AC 3030-K	10740	300	400	300	220	320	150	1	70	11
AC 3030-E	10738									
AC 3040-K	10741	300	400	400	220	320	250	1	88	18
AC 3040-E	10739									

SAFE DEPOSIT BOXES

Features

Modular lockers for storing high-value items

Door shielding thickness: 6 mm.

Body thickness: 2 mm.

Stackable both vertically and horizontally

Colour: Standard gray, for other RALs, consult.

Custom-made base available, depending on the number of arms dealers per column.

Anchor holes: 2 floor, 2 wall.

Lock: Safety point lock

Master key option for opening all locks.



Individual locker

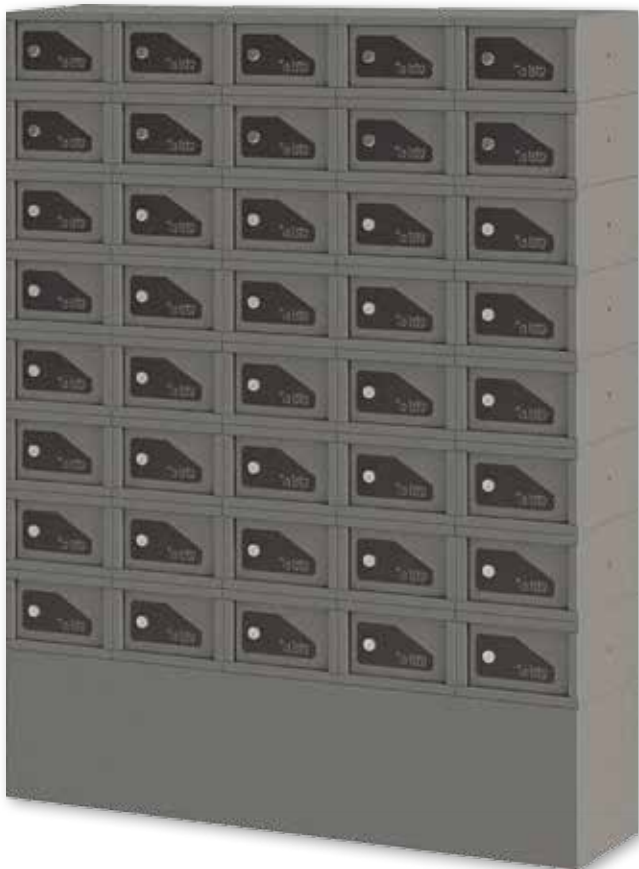

Example of 40 lockers distribution



Example of grouping layout

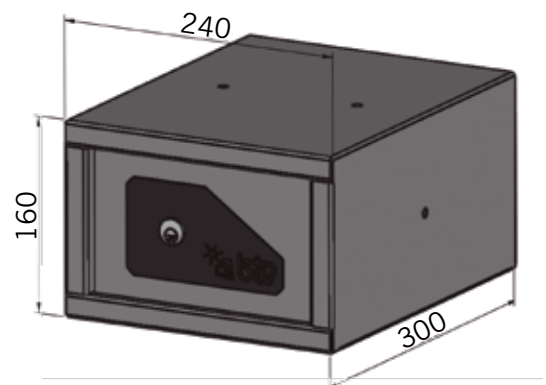

Model	Code	Ext (Hi x Wi x D)			Int (Hi x Wi x D)			kg	L
Individual locker	80110	160	240	300	152	236	292	6	10

European Safe standards



It was formerly thought that the resistance of a safe deposit box in an attempted robbery was directly related to the weight or the thickness of its walls. Today manufacturers of safes incorporate advanced materials as well as closing elements that have been previously tested in independent sector reference laboratories.

The tests consist of the determination of the time needed to access the interior of the safes using various tools. The more time, the higher the level of resistance. Depending on the outcome of these trials, safes are classified according to their grade or level of security. Security is no longer a matter of 'weight', but of technology.

In Europe both insurance companies and the most demanding customers have begun to use security level classification of the 3 main technical standards of reference (in an attempted robbery or fire).

A certified box is a guarantee of a good buy. Organizations accredited to certify this product, such as AENOR in Spain or the ECBS at a European level, perform periodic audits in our factory which guarantee that the manufacturing processes produce identical products to the tested safes in their laboratories.

UNE-EN-1143-1:2012: BURGLARY RESISTANT SAFES

11 resistance grades, from 0 to X, 0 being the lower level and X the highest. From grade V, tests include post-detonation tests. The standard includes anchoring system resistance tests, as well as the requirement of exclusive use of certified locks.

BTV series: Babylon (II), Athenas (III), Athenas 175 (III), Athenas AC-30 (III), Luxor (IV), Thebas (IV), Gas station (IV) and Alexandria (V) certified according to this standard.

Spanish law contemplates the need for installation of grade IV certified safes in certain stores, such as jewellery stores, bank offices, lottery dealers and gas stations.

UNE-EN-14450: BURGLARY RESISTANT SECURE SAFE CABINETS

2 burglary resistance levels. Focused on safes with robust construction, but lighter than grade 0, according to the previous standard. Level S2 is superior to S1.

BTV series Cuarzo (S2), Rubí (S2) and Ignis (S2) are certified according to this standard.

UNE-EN-15659: FIRE PROOF

This classifies safes in 2 different levels of resistance according to the increase of temperature in case of fire: 30 or 60 minutes (LFS 30 P and LFS 60 P). It guarantees that the inner temperature is under 170 °C (documents are always kept below the burn point).

BTV series Vulcano (LFS 60 P), Solid (LFS 30 P), Filing Cabinet Ignis (LFS 60 P) and Fireproof Briefcases (LFS 60 P). Ignis cabinet series is fireproof for 30 minutes against fire according to the standard GOST R50862.



General sales conditions

FEES AND PAYMENTS

- The fees and conditions included come into effect on **March 15th 2018** and replace all published before that date.
- All prices are per unit, excluding VAT.
- Delays in payment on the agreed date of expiration, will charges interest rate of 0,75% per month (9% per year).
- OFFERS FOR ONLINE ORDERS: Any orders that clients place through the BTV Client Portal will have a 1% additional discount on the net price of the order. 3% discount for the first order, and cannot be accumulated with the 1%.

PACKAGING

- Packaging is included in the price.
- The price always refers to the number of units or multiple of them in a full package.

SHIPPING

- The shipping is carriage-paid to the client's doorstep at ground level, for orders over the following net amounts per invoice, according to the area:

Spain (peninsula):	200,00€
Ceuta and Melilla:	260,00 € (exportation expenses by the client).
Balearic islands:	260,00€
Canary islands:	900,00€ (exportation expenses by the client).
Portugal:	600,00€
Andorra:	260,00€ (DUA by the client).

*Other destinations: Please ask our sales department.

- If orders are under these amounts, shipments will be carriage forward or the shipping costs will be charged onto an invoice. Specifically for shipments to Spain (peninsula), the following fixed amounts are loaded:

Since 50€:	10,00€
More than 50 to 200€:	13,00€

Canary islands:	39,00€	orders from 0 to 300 €
	49,00€	orders more than 300 to 600 €
	59,00€	orders more than 600 to 900 €

Balearic islands:	15,00 €	orders from 0 to 50 €
	20,00 €	orders more than 50 to 260 €

Andorra:	10 €	orders from 0 to 50€
	13 €	orders more than 50 to 260€

Portugal:	21,00€	orders from 0 to 300€
	30,00€	orders more than 300 to 599€

MINIMUM ORDERS

- BTV DOESN'T establish a minimum amount per order.

RETURNING GOODS

- We will only accept returned goods that are clearly identified with the AUTHORISED RETURN CODE, which the client must request from BTV before sending the goods back.
- Special, customised or discontinued products cannot be returned.
- BTV will manage the return transport if the reason for returning the product is attributable to BTV.
- For returns attributable to the client, returned goods will only be accepted during the first 15 calendar days after shipping goods.
- In case of returns for reasons attributable to the client, 90% of the value of the original product will be refunded, but only if the product is returned in good technical conditions and its original packaging. If products returned are damaged or do not include the original packaging, at least another 20% will be knocked off.
- The client must make sure that the goods are in perfect condition before signing the delivery note. After shipping, the client is responsible for the condition of the goods and will have 24 hours to make a claim to the agency if there are any damages caused during transportation. If BTV or the agency does not receive any claims in this period of time, the client will have to pay for the repair.
- To make a claim for goods damaged during transport, the client must send a photograph of the damaged goods to our factory. This photograph will make the damage assessment easier, and will facilitate refund or a new estimate for repair.

MODIFICATIONS ON PRODUCTS

In order to improve constantly, the company reserves the right to modify any of the technical features or looks of its products at any time. The features that appear in the catalogue are for illustrative purposes and are not binding.

Therefore, any diagrams, figures, dimensions, weights or any other information in the catalogue will only be binding if they have been agreed in writing.





btv@btv.es
www.btv.es

Headquarter & factory Zaragoza (Spain)

Address

Ctra. Nacional II, Km. 333
Polígono Industrial BTV - Alfindén
50171 La Puebla de Alfindén
(Zaragoza) Spain
Tel. +34 976 108 088
International: +34 976 108 422
Office mobile phone: 615 072 531



Consults sales department
616 996 303 (no orders)

Jiaying factory (China)

Tel. +86 0573 82759908

Office and warehouse in Cancun (Mexico)

Tel. (998) 887 4490
www.btmexico.com

Technical Support

902 190 386

Customer Service

902 877 873



 Our catalogue in
your phone